

## Coils in 20' box containers: General information and options

### Winding axis lying lengthwise

Forklift trucks can only be used for direct handling of low mass coils of up to approx. 2.5 metric tons. Heavier coils must be pushed into the container. This requires special working methods in order to prevent tearing of the strapping and to avoid bruising the coils.

Coils can be pushed in if auxiliary materials are used which have a high [coefficient of sliding friction](#) on the coil side and a lower coefficient of sliding friction on the outside. If this is the case, the materials stick to the coil and are "entrained" as the coil is pushed in.

Suitable cradles must be prepared before loading is begun.

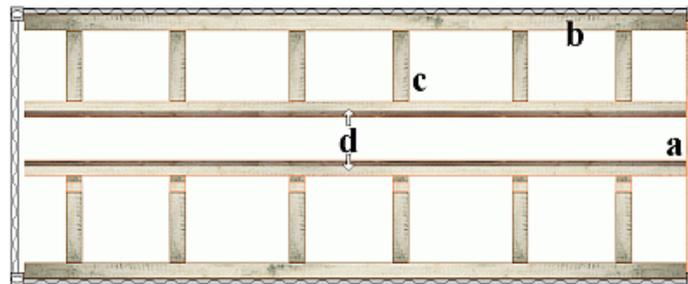

Coil [cradle](#) - plan view

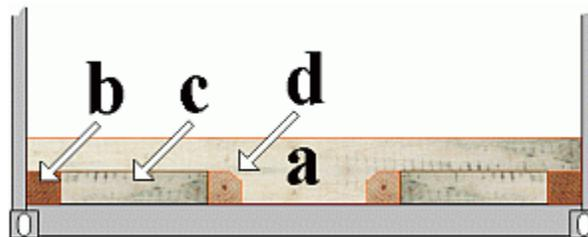

Using boards or planks, the front end wall is braced (a) flush with the corner posts up to twice the height of the lumber size used. Squared lumber (b) is laid down at the sides of the container to distribute pressure. Depending upon the number of coils to be loaded and their mass, crosspieces (c) are laid at right angles to the side beams. Wedge members (d) are then laid lengthwise.

N.B.: Since the coils are subsequently to be [lashed](#), the lashing points must remain accessible. Should these be located under the lengthwise beams (b), the necessary lashing means can be attached to the lashing points before the wooden members are laid. The lengthwise beams (b) can then be placed on small boards.

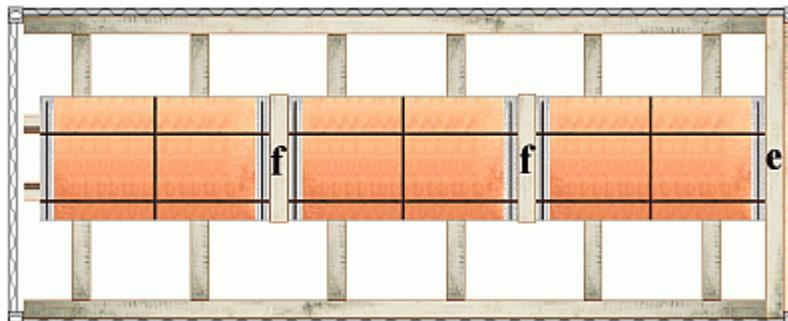

Loading and interim securing of coils - plan view

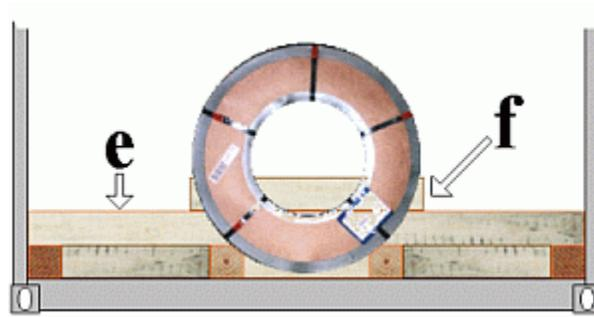

Loading and interim securing of coils  
- cross-section

Before loading begins, a beam (e) is laid crosswise in front of the boards or planks (a) and the corner posts. This beam (e) lies on the lengthwise members (b) and (d). The first coil is laid against this crosswise beam (e). A shorter beam (f) acting as a spacer relative to the next coil is laid crosswise over the wedge beams (d) and the second coil is loaded against it. The same method is used for the third coil. (f) is at the level of (e) and is only shown higher to make it more visible.

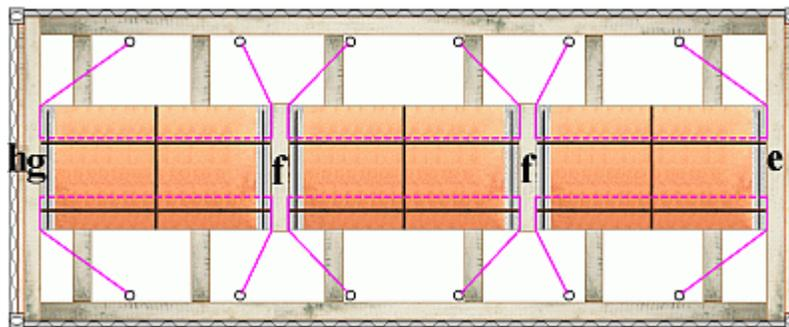

Three coils: blocked and lashed - plan view

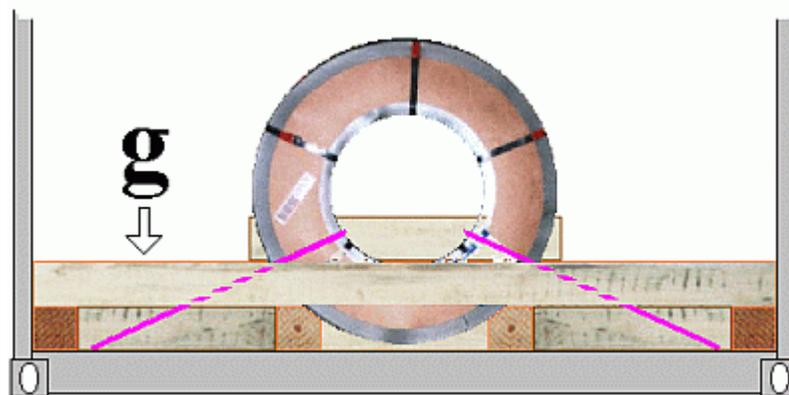

Three coils: blocked and lashed - cross-section

Once the last coil has been placed, the remaining gap towards the container door is filled with squared lumber (g) and boards or planks (h). Each coil is secured with two loop lashings passed through the eye. These lashings secure the coils laterally and prevent them from popping vertically out of the wedge beams under dynamic loads

Recommendation:

Coils stowed with the axis pointed to the end of the container:

1. Weight of coils always to be distributed as 1.5m.t per cross member equal to max. 5 mt /meter
2. To distribute the weight, the coils should be stowed on wooden supporting battens. Except for coils less than 3mt, the lowest point of the coil may never be in touch with the floor. Length of supporting batten not to exceed the width (length) of the coil by 60cm.
3. For coils less than 3m.t. battens may not be required but anyway lateral wedging has to be provided in addition to chocking.

| <b>4. Weight of coil</b> | <b>Size of supporting battens</b> | <b>Width</b> |
|--------------------------|-----------------------------------|--------------|
|--------------------------|-----------------------------------|--------------|

|                    |                |      |
|--------------------|----------------|------|
| A. Less than 5m.t  | Square 15x15cm | 1.2m |
| B. 5 – 9m.t        | Square 15x15cm |      |
| C. C. 9 – 12m.t    | Square 20x20cm |      |
| D. More than 12m.t | Square 30x30cm |      |

5. Lashing to be carried out with use of chocking by 10x10cm batten (square dimension) to half-height of the coil, minimum 3 pieces per coil supporting to the side of the container. Also fore and aft end to be chocked off with dunnage of 10x10cm nailed to for and aft battens on which the coil rests.

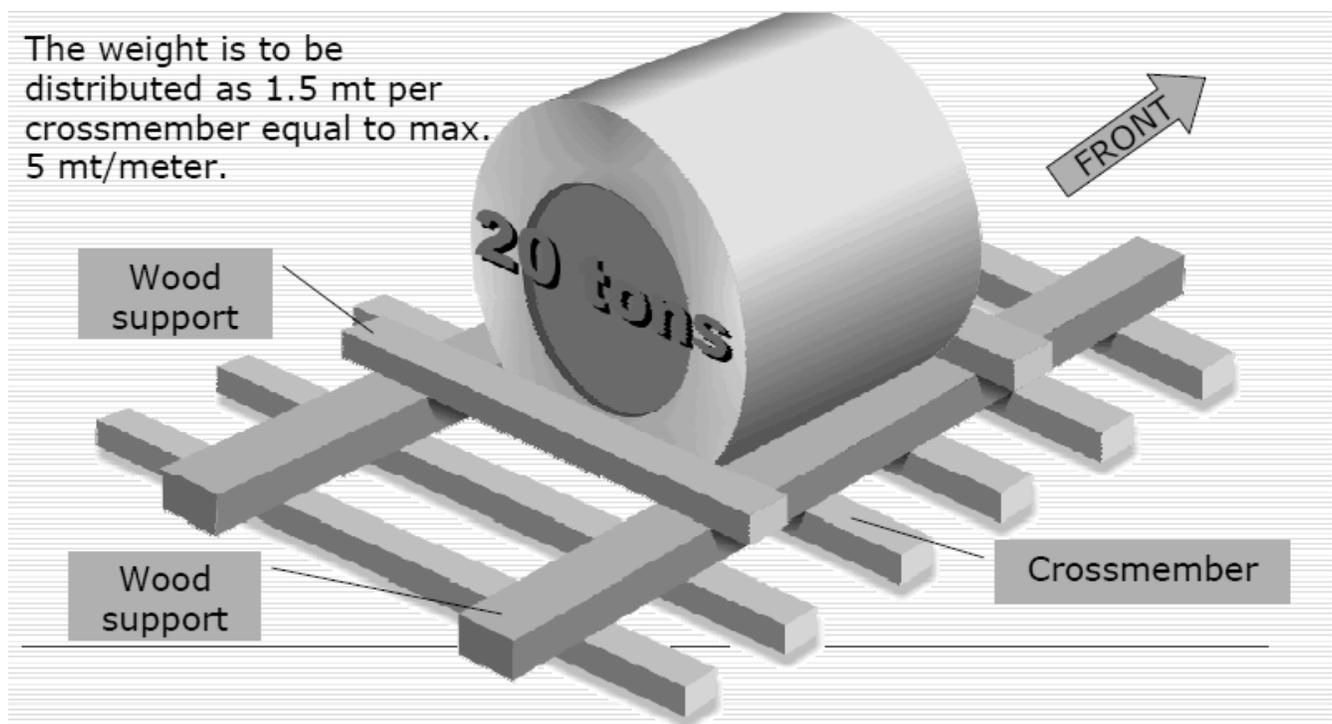

## Lashing and Binding Check Form

| No | Check Points  | Compliance |   |     | Objective Evidence &Comments |
|----|---|------------|---|-----|------------------------------|
|    |   | Y          | N | N/A |                              |
| 1  | Are there wooden batten as supporting batten nailed on the floor of container?                    | x          |   |     |                              |
| 2  | Are the wooden battens settled at center part of container?                                       | x          |   |     |                              |
| 3  | Are the cargo stowed on the battens evenly?   | x          |   |     |                              |
| 4  | Are steel coils stowed closed each other?   | x          |   |     |                              |
| 5  | Are wooden wedges chocked to prevent cargo moving at anyone direction?                            | x          |   |     |                              |
| 6  | Are the chocked wooden wedges effectively prevent cargo moving on the view of quantity and shape? | x          |   |     |                              |
| 7  | Are suitable steel wires used to secure the cargoes in integrity?                                 | x          |   |     |                              |
| 8  | Are connection component used to lock the steel wires?  | x          |   |     |                              |
| 9  | If is the lashing end secured in the lashing eye of container?                                    |            | x |     |                              |
| 10 | Is the wooden cradle designed to fix the cargoes from moving?                                     |            | x |     |                              |

## Coils on skids, horizontal winding axis

Coils with horizontal winding axis on skids

There is no need to address the securing of these cargoes separately. Where possible, packing should be carried out so that the lower layers of the wooden sled members are at right angles to the container bottom cross members. If dimensions do not permit this, the cargo must be packed either crosswise or lengthwise. If the bottom wooden sleds members run parallel to the container bottom cross members, it must be verified that the container **line load** is not exceeded. If this is the case, additional wooden members must be provided to distribute the pressure. Any remaining gaps should be filled with lumber at the height of the load-bearing parts. Loop lashings should also be passed through the eye to provide further securing. If bracing and/or loop lashings are not enough, or if they are difficult or impossible to apply, the option still remains of applying **shoring** against the load-bearing wedge beams or the other wooden sled members encompassed by the strapping. In individual cases, subject to compliance with the basic rules for using airbags, it may be possible to use airbags alone or in addition to other securing means. Where possible, friction-enhancing materials should be laid under the **skids**. If the cargo has to be slid into its stowage space, such materials can only be laid, if at all, once the cargo is in position. This requirement also applies to the following examples.

### Recommendation (See Picture):

Alternatively, coils loaded with the core axis pointed to the sides

1. Only applicable for coils with weight up to 8 m.t.
2. Coils to be supported by 3 battens of 15x15cm square over the length of the container.
3. Coils to be stowed equally spaced over the length of the container.
4. Adequate chocking to be applied between one third of the coil-height and the side of the container.
5. Very important is to chock off the void space in between the coils and/or the ends of the container with the use of 10x10cm dunnage in order to avoid rolling over of coils during road or rail transport.
6. Loop lashings must also be passed through the eye to provide further securing



## Coils on skids, vertical winding axis

Coils and slit strip coils with a vertical winding axis

Before loading, attachment to the skids should be checked. If the method of application or condition of the straps gives the impression that they could slacken or be unable of withstanding anticipated acceleration forces, additional attachment to the skids should be ensured.



Slit strip coils - fastened onto wooden sleds with steel strapping

Depending on their dimensions, coils should where possible be packed without gaps. Any remaining gaps should be filled with lumber members. Lashings may be passed through the eye, but only if the coil is not completely shrink-wrapped. If lashings cannot be passed through the eye, shoring is very effective in preventing slit strip coils from moving.

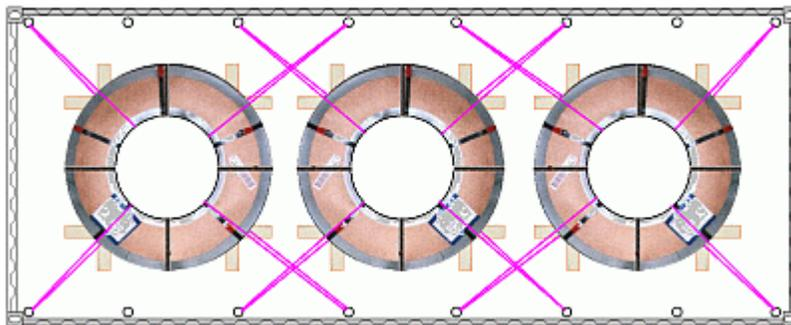

Securing of coils/slit strip coils with loop lashings passed through the eye - plan view

Depending on the mass of the cargo and the maximum securing loads of the lashings, this method may be adequate by itself. With high cargo masses or low maximum securing loads of the lashings, additional measures should be taken.

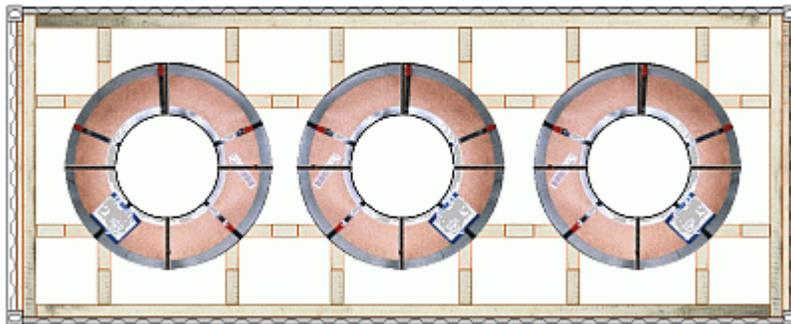

Securing coils/slit strip coils with wooden bracing  
- plan view

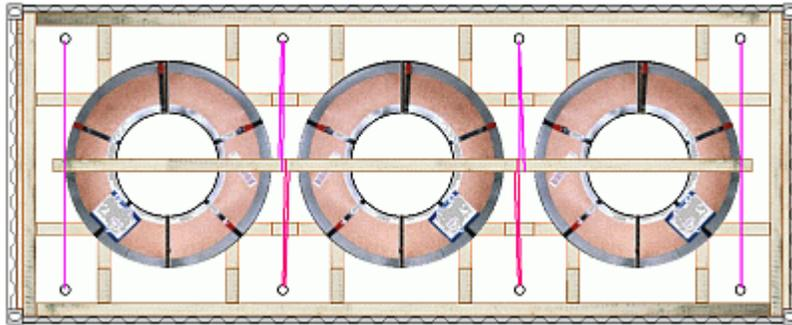

Securing with squared lumber and hold-down members

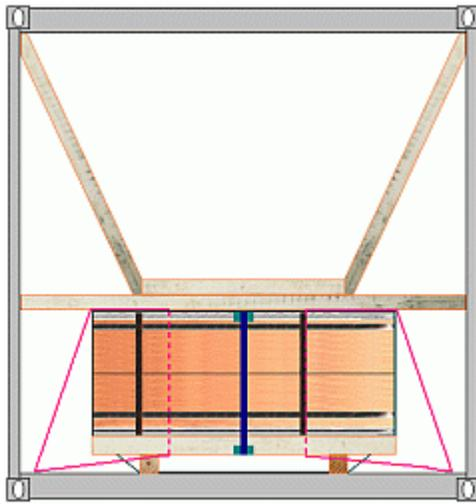

Securing with loop lashings through the eye and shoring - plan view

Passing loop lashings through the eye has the advantage that the load on the strapping is relieved.

### Liability

Please note that all possible repairs for noticed damages to the CSAV equipment involved will be reverted for collecting from the Named Shipper.

**Damages caused by coils due to wrong stowage.**  
Examples of Wrong Shipments



